

JET

DC-1900A

DC-1900CK

DUST COLLECTOR

DC-1900A 708638T.....3~400V, 50Hz

DC-1900CK..... 708638CKT3~400V, 50Hz

PARTS LIST

JPW (Tool) AG

Tämperlistr. 5

CH-8117 Fällanden

Switzerland

Phone +41 44 806 47 48

Fax +41 44 806 47 58

www.jettools.com

P-708638T, 708638CKT 2015-10



Parts Breakdown for DC-1900A / DC-1900CK Dust Collector

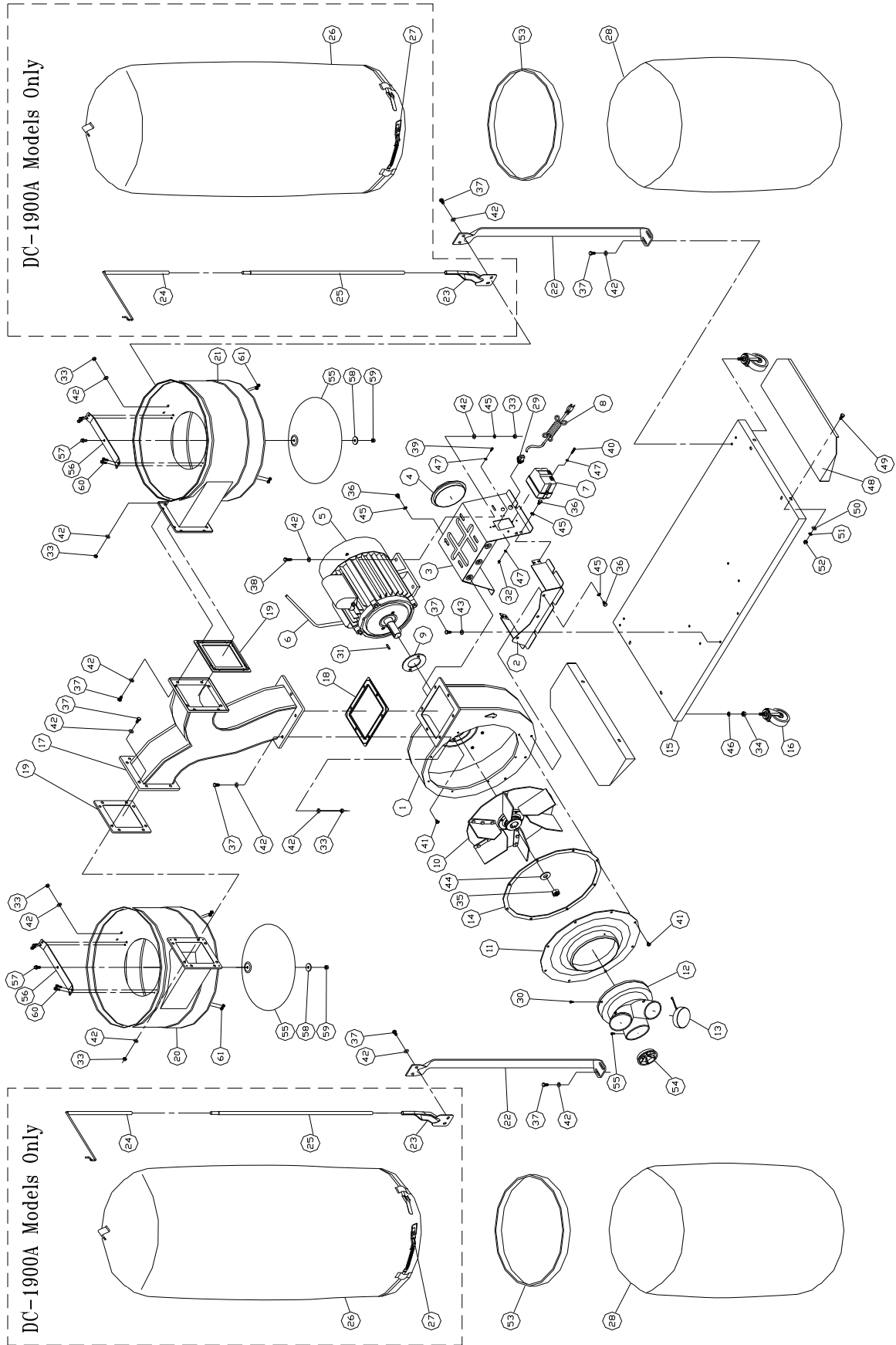

Parts List for DC-1900A / DC-1900CK Dust Collector

Index No.	Part No.	Description	Size	Qty.
1	431018W	Impeller Housing		1
2	431019W	Impeller Housing Bracket		1
3	431020W	Motor Bracket		1
4	450038	Bracket Cap		1
5	DC-1900-005AE	Motor	3HP, 3Ph, 400V	1
	DC-1900-MFC	Motor Fan Cover (not shown)		1
	DC-1900-MF	Motor Fan (not shown)		1
6	VA15041206Y2RE80	Motor Cord		1
7	ID33021H	Magnet Switch with Overload protection..	3PH	1
8	DC-1900-008AE	Power Cord	1.5mm ² x4C	1
9	420051	Motor Pad		1
10	431006	Impeller	14"	1
11	431008W	Inlet Cuard	8"	1
12	431025	Inlet Port	4"x3	1
13	420203	Inlet Cap		2
14	431034	Rubber Gasket		1
15	430028W	Base		1
16	402036	Pivoting Caster		4
17	430004W	Connector		1
18	430035	Rubber Gasket		1
19	430036	Rubber Gasket		2
20	430012W	Left Housing		1
21	430020W	Right Housing		1
22	402004W	Support Bar		2
23	523011W	Hanger Bracket		2
24	430039	Upper Hanger		2
25	430037	Support Bar		2
26	708689	Filter Bag		2
27	430005	Retainer Strap		2
28	709563	Collection Bag		10
29	136013	Strain Relief		2
30	990855	Pan Head Screw	3/16 x 1/2"	1
31	992021	Key	7x7x20	1
32	991213	Hex Nut	3/16"	1
33	TS-1540061	Hex Nut	M8	30
34	TS-0561031	Hex Nut	3/8" -16 UNC	4
35	TS-0561072	Hex Nut	5/8" -18 UNF	1
36	TS-1490011	Hex Head Bolt	M8x12	10
37	TS-1490031	Hex Head Bolt	M8x20	36
38	TS-1490041	Hex Head Bolt	M8x25	4
39	990855	Pan Head Screw	3/16 x 1/2"	1
40	990856	Pan Head Screw	3/16 x 1"	2
41	TS-1554041	Pan Head Screw	M6x12	10
42	TS-0680031	Flat Washer	M8	64
43	TS-1550071	Flat Washer	M10	6
44	TS-155010	Flat Washer	M16	1
45	TS-0720081	Lock Washer	M8	14
46	TS-1551071	Lock Washer	M10	4
47	WE050000	Star Washer (Ext)	M5	4
48	DC-1900-048E	Extension Plate		2
49	TS-1490031	Hex Head Bolt	M8x20	4
50	TS-1550061	Flat Washer	M8	4
51	TS-2361081	Lock Washer	M8	4
52	TS-1540061	Hex Nut	M8	4
53	331038	Snap Ring		2
54	420937	Inlet Guard		3

Parts List for DC-1900A / DC-1900CK Dust Collector

Index No.	Part No.	Description	Size	Qty.
.....	DC1100-CA	Cone Assembly (# 55 ~ 61)		2
55	DC1100-47	Cone		2
56	DC1100-47-1	Support Bracket		2
57	TS-1490021	Hex Cap Screw	M8x16	2
58	TS-1550061	Flat Washer	M8	2
59	TS-1540061	Hex Nut	M8	2
60	TS-1482021	Hex Cap Screw	M6x12	8
61	TS-2311061	Hex Nut	M6	8
.....	DC1900-HP	Hardware Package for Base Unit		1
.....	DC1100-HP2	Hardware Package for Cone Assembly		2

708739.....Canister Filter Assembly for DC-1900CK Models

Index No.	Part No.	Description	Size	Qty.
1	708739	Canister Filter Assembly (# 1 ~ 22)		1
2	331037	Knob	M6x20	4
3	331031	Pad		1
4	331009	Support		1
5	ST049200	Tapping Screw	M4x8	4
6	TS-1540071	Hex Nut	M10	2
7	TS-1550071	Flat Washer	M10	2
8	331050	Handle		1
9	331051	Soft Grip Handle		2
10	TS-2361101	Lock Washer	M10	1
11	BR000052	Rivet	5-2	3
12	331014	Bracket		1
13	150623	Pad		1
14	TS-1540041	Hex Nut	M6	8
15	331052	Shaft		1
16	TS-1482041	Hex Cap Screw	M6x20	4
17	TS-2361061	Lock Washer	M6	4
18	TS-1550041	Flat Washer	M6	4
19	331012	Scraper		2
20	331017	Strip		2
21	331015	Press Plate		2
22	TS-1482021	Hex Cap Screw	M6x12	4

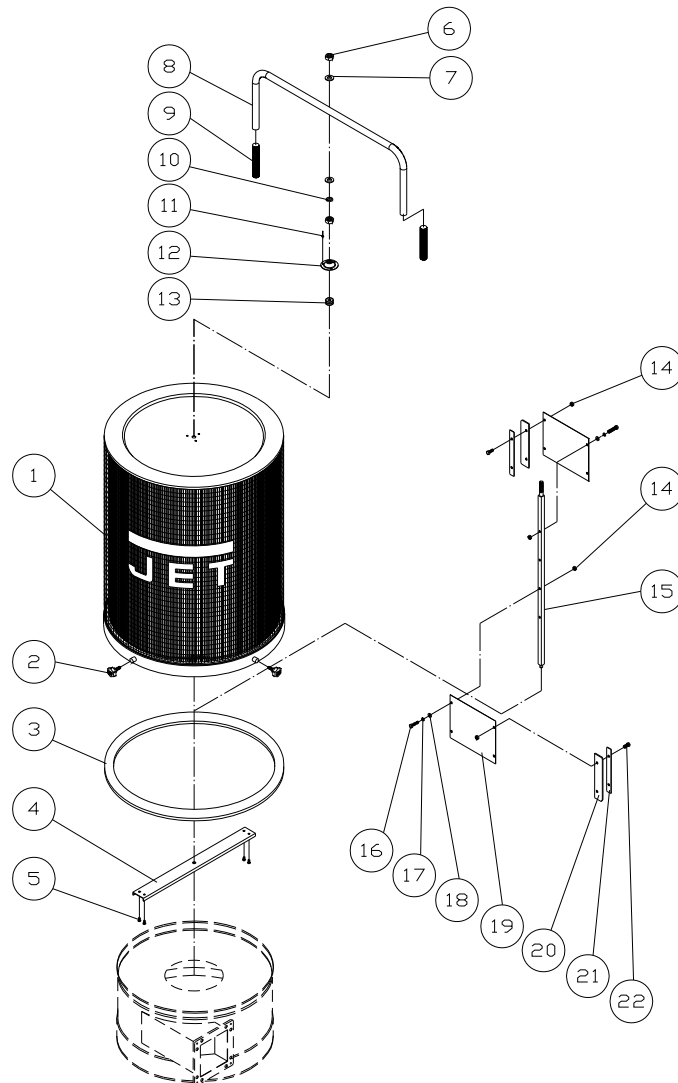

DC-1900A 708638T.....3~400V, 50Hz

DC-1900CK..... 708638CKT3~400V, 50Hz

400V / 3~

	colour of strands	Litzenfarben	couleur des cordons
BK	black	schwarz	noir
WH	white	weiß	blanc
BU	blue	blau	bleu
YE	yellow	gelb	jaune
RD	red	rot	rouge
BN	brown	braun	brun
GY	grey	grau	gris
GNYE	green-yellow	grün-gelb	vert-jaune
OG	orange	orange	orange
VT	violet	violet	violet

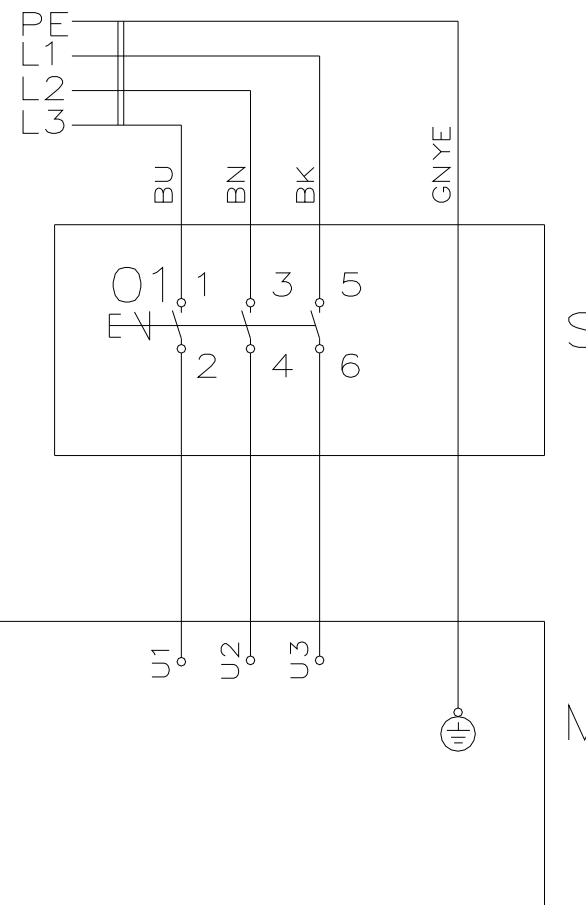

	meaning of symbol	Bedeutung der Zeichen	interprétation
M	motor	Motor	moteur
S	switch	Schalter	interrupteur
C	condenser	Kondensator	condensateur
E	electronic unit	Elektronik Einheit	unité électronique
F	fuse	Sicherung	fusible
RS	reversing switch	Drehrichtungsschalter	commu. droite/gauche
CS	centrifugal switch	Fliehkraftschalter	déclencheur centrifuge
OL	overload cut-off	Überlastschutzschalter	déclencheur surcharge
LS	limit switch	Positionsendschalter	micro